

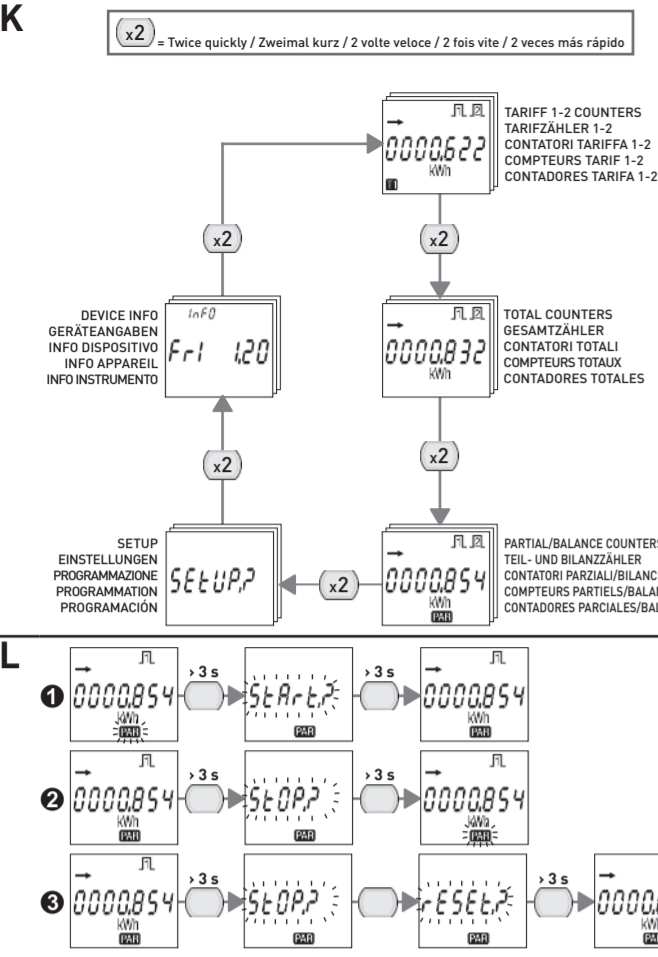

PICTURE/ABBILDEN/FIGURA/FIGURE/IMAGEN

EN - 80A SINGLE PHASE ENERGY METER



BALANCE COUNTER VALUES CALCULATION table with columns for BALANCE COUNTER, FORMULA, and KEYS. Includes sections for KEY FUNCTIONS, PAGE STRUCTURE, HOW TO START, and HOW TO SETUP.

DE - 80A EINPHASIGER ENERGIEZÄHLER

BILANZZÄHLERWERTE BERECHNUNG table with columns for BILANZZÄHLER, FORMEL, and FUNKTION. Includes sections for TASTENFUNKTIONEN, ANZEIGE REIHENFOLGE, and EINSTELLSEITEN.

IT - CONTATORE DI ENERGIA 80A MONOFASE

CALCOLO PER I VALORI DEI CONTATORI DI BILANCIO table with columns for CONTATORE DI BILANCIO, FORMULA, and FUNZIONALITA'. Includes sections for FUNZIONI DEI TASTI and STRUTTURA PAGINE.

FR - CAPTEUR D'ENERGIE MONOPHASE 80A

CALCUL POUR LES VALEURS DES COMPTEURS BALANCES table with columns for COMPTEUR BALANCE, FORMULE, and FONCTIONS. Includes sections for FONCTIONS DES TOUCHES and STRUCTURE DES PAGES.

ES - CONTADOR DE ENERGIA 80A MONOFÁSICO

CÁLCULO DE LOS VALORES DE LOS CONTADORES DE BALANCE table with columns for CONTADOR DE BALANCE, FORMULA, and FUNCIONES. Includes sections for FUNCIONES DE LAS TECLAS and ESTRUCTURA PÁGINAS.

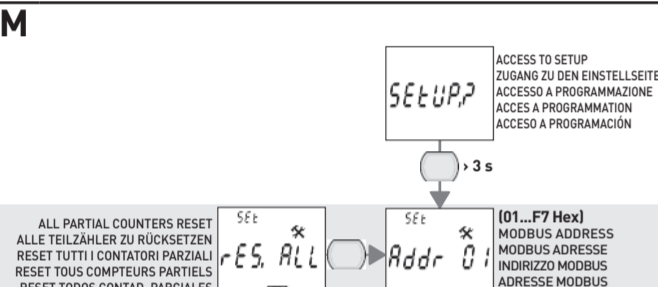

SETUP PAGES (picture M) section with instructions for setting up the meter. Includes a table for key functions and a flowchart for the setup process.

EINSTELLSEITEN (Bild M) section with instructions for setting up the meter. Includes a table for key functions and a flowchart for the setup process.

PAGINE PROGRAMMAZIONE (figura M) section with instructions for programming the meter. Includes a table for key functions and a flowchart for the programming process.

PAGES PROGRAMMATION (figure M) section with instructions for programming the meter. Includes a table for key functions and a flowchart for the programming process.

PÁGINAS PROGRAMACIÓN (figura M) section with instructions for programming the meter. Includes a table for key functions and a flowchart for the programming process.

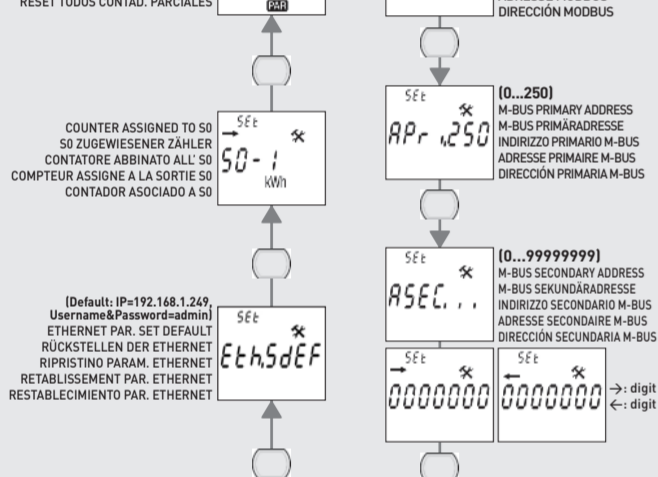

INFO PAGES section with instructions for accessing information pages. Includes a table for key functions and a flowchart for the info page process.

INFO SEITEN section with instructions for accessing information pages. Includes a table for key functions and a flowchart for the info page process.

PAGINE INFO section with instructions for accessing information pages. Includes a table for key functions and a flowchart for the info page process.

PAGES INFO section with instructions for accessing information pages. Includes a table for key functions and a flowchart for the info page process.

PÁGINAS INFO section with instructions for accessing information pages. Includes a table for key functions and a flowchart for the info page process.

TECHNICAL FEATURES section with a table listing technical specifications for the meter. Includes sections for GENERAL, POWER SUPPLY, CURRENT, ACCURACY, and COMMUNICATION.

TECHNISCHE EIGENSCHAFTEN section with a table listing technical specifications for the meter. Includes sections for GENERAL, HILFSPANNUNG, STROM, GENAUIGKEIT, and KONTAKTION.

CARATTERISTICHE TECNICHE section with a table listing technical specifications for the meter. Includes sections for GENERAL, ALIMENTAZIONE, CORRENTE, PRECISIONE, and COMUNICAZIONE.

CARACTERÍSTICAS TÉCNICAS section with a table listing technical specifications for the meter. Includes sections for GENERAL, ALIMENTACIÓN, CORRIENTE, PRECISIÓN, and COMUNICACIÓN.

CARACTERÍSTICAS TÉCNICAS section with a table listing technical specifications for the meter. Includes sections for GENERAL, ALIMENTACIÓN, CORRIENTE, PRECISIÓN, and COMUNICACIÓN.

CARACTERÍSTICAS TÉCNICAS section with a table listing technical specifications for the meter. Includes sections for GENERAL, ALIMENTACIÓN, CORRIENTE, PRECISIÓN, and COMUNICACIÓN.