



Metal conduit system "Cosmec"



Advantages
System composition
Accessories

Metal conduit system

Application

The system of metal conduits for wiring is designed for reliable protection of cables in industrial equipment and commercial property. Material of uncoated conduits is non-combustible and applied in different fields, where it is necessary to ensure thermal stability and increased resistance to mechanical damage. High flexibility, wear resistance, ability to withstand impact loads, ultraviolet light, aggressive exposure to oils, solvents and different fuel types, protection against electromagnetic effect are undeniable advantages of the metal conduit system. The system of metal flexible conduits with different types of vacuum insulation and rigid conduits with the use of connectors allows forming a reliable wiring system with high dust and moisture protection degree.

Zinc coating thickness

- metal flexible conduit is made of high-quality steel according to EN 10346, and galvanized by the Sendzimir method;
- service life of a galvanized metal flexible conduit within premises with the moderate climate comprises at least **15 years**

Non-combustible material

- mounting and operating temperature from -45 to $+250$ °C

Accessories

- perfect mating of conduits with connectors;
- perfect sealing (for coated conduits);
- easy and reliable installation;
- wide range of connectors

Advantages of reinforced lock

- high tear strength;
- high indicator of relative elongation in case of tear;
- excellent reliability under bending due to the shape of a lock hook

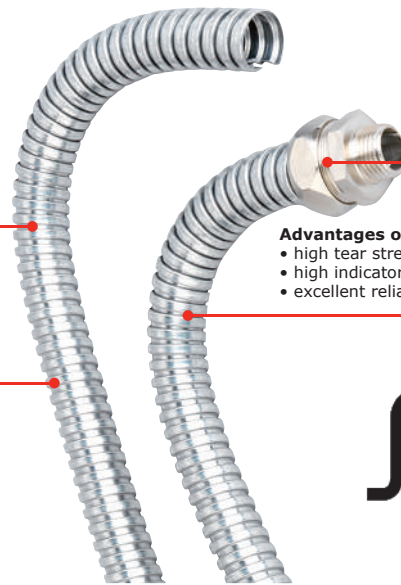

Reinforced lock



Ordinary lock

Assortment

A wide array of standard sizes of flexible and rigid conduits and connectors thereto with different types of coatings and basic materials makes it possible to create a system of any complexity which meets any and all requirements to temperature conditions, chemical resistance and mechanical strength to the full extent.

The unique patented system of conduits and connectors made of stainless steel of AISI 304 and AISI 316L grades for application at facilities of food and chemical industry.



Metal flexible conduit made of galvanized steel, IP40



Metal flexible conduit in smooth PVC insulation



Metal flexible conduit in vacuum PVC insulation



Metal flexible conduit in PVC insulation, protected by galvanized steel braid



Metal flexible conduit in smooth EVA insulation



Metal flexible conduit in smooth EVA insulation and protected by stainless steel braid



Galvanized conduit



Coupling for metal flexible conduit



Rotary coupling for metal flexible conduit



Coupling for metal flexible conduit, inside thread



Conduit-conduit coupling IP66/IP67



Conduit-box coupling, IP66/IP67



Conduit-box coupling, IP66/IP67, inside thread



Metal flexible conduit coupling, IP66/IP67



Nut



Grounding nut



Sealing gasket IP67

Distinctive features of connectors for metal flexible conduits

Metal flexible conduit

Made of galvanized steel
in vacuum coating

Clamping nut

- nickel-plated brass;
- high chemical resistance;
- 6 edges for tightening with an open end wrench

Coupling enclosure

- nickel-plated brass;
- perfectly smooth internal surface excludes the possibility of cable damage when pulling;
- high strength and reliability of couplings;
- high chemical resistance

Thread

Metric thread according to EN 60423

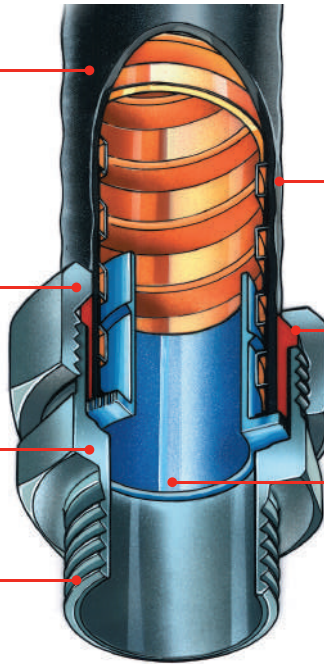

Continuity of electric circuit with connectors

- electrical continuity of "Cosmec" metal flexible conduits in the system with connectors;
- grounding of a metal flexible conduit without soldering and failure of vacuum insulation of a metal flexible conduit;
- special grounding nut for connection to painted grounded equipment (purchased separately)

Polyamide clamping ring

Reliably attaches a coupling on a conduit, providing high sealing degree IP67

ZAMAK zinc alloy bushing

- covers sharp edges of a metal flexible conduit, excluding the possibility of damage to a cable or a wire when pulling;
- screwed in a metal flexible conduit, providing high tear-out load

Distinctive features of connectors for metal conduits

Rigid steel conduit

Locking ring

It is sufficient to press on a lock for simple removal of a conduit from a connector

Coupling enclosure

- nickel-plated brass;
- perfectly smooth internal surface excludes the possibility of cable damage when pulling;
- high strength and reliability of couplings;
- high chemical resistance

Thread

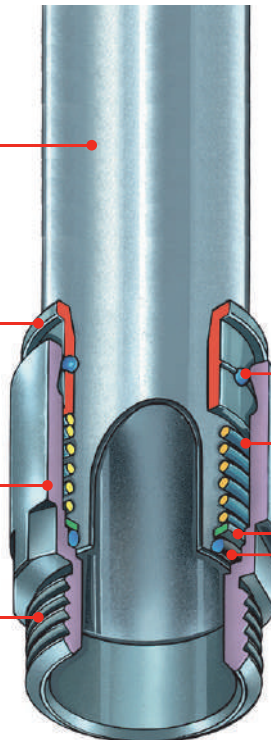

Patented system of attachment with steel balls

Simple mating of a conduit with a connector

- performed by simple latching;
- minimum installation time;
- does not require threading, welding and special tools

High connection reliability

- 6 balls capture a conduit on all sides and hold it reliably in a connector;
- balls are blocked in a coupling enclosure groove;
- does not damage conduit zinc coating

Spring

- reliable attachment of a conduit in a connector;
- reliable seal attachment

Protective ring for seal attachment

Reliably attaches and protects a seal against damages

Toric seal

Installed in the coupling enclosure. Provides perfect sealing IP66/IP67



www.dkc.info